

# 5KWH WALL-MOUNTED

LiFePO4 Lithium Iron Phosphate Battery



## USER MANUAL

# Product Description

| Technical Specifications    |                  |
|-----------------------------|------------------|
| Battery Type                | LiFePO4(LFP)     |
| Normal Voltage(V)           | 51.2V            |
| Normal Energy(KWH)          | 5.12KWH          |
| Design Capacity             | 100AH            |
| Design Years                | 15 Years         |
| Product Size                |                  |
| Size                        | 600*510*173mm    |
| Weight                      | 51kg             |
| Technical Parameter         |                  |
| Cycle Life                  | ≥6000 80% DOD    |
| Operating Voltage Range     | 40V-58.4V        |
| Charging Voltage            | DC 58.4V         |
| Charge/Discharge Current(A) | Same Port 100A   |
| Internal Resistance         | ≤30m Ω           |
| BMS Parameters              |                  |
| Self-Consumption            | ≤2W              |
| Rated Voltage               | 51.2V            |
| Balance Current             | 30-65(MA)        |
| Communication Method        | CAN/RS485/RS232  |
| Information Storage         | 500 Strip        |
| Limiting                    | 10/20A(Optional) |
| Ambient Temperature         |                  |
| Operating Temperature       | -10 C -50 C      |
| Storage Temperature         | 10 C -50 C       |
| Humidity                    | 15%-75%          |
| Warranty                    |                  |
| Warranty                    | 5 Years          |



## Smart

Each module is equipped with an independent BMS system.



## Easy Installation

Just Plug & Play.



## Safe

Safe lithium iron phosphate battery cell.



## Certifications

CE IEC  
UN38.3 MSDS.



## Modular

Modular expansion.



## Longer Lifetime

6000 cycles, 15 years design life.



Lithium battery systems are widely used in residential energy storage systems, such as solar energy storage systems and UPS. The power wall LiFePO4 battery pack adopts the international advanced lithium iron phosphate battery application technology and BMS control technology.

## Product Size:

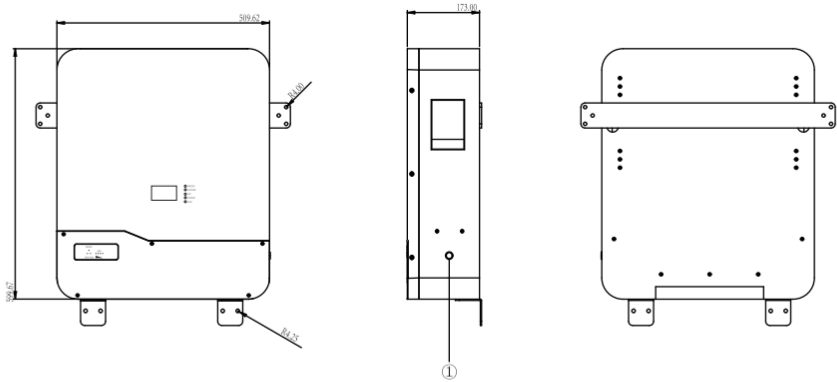

## Product Interface:

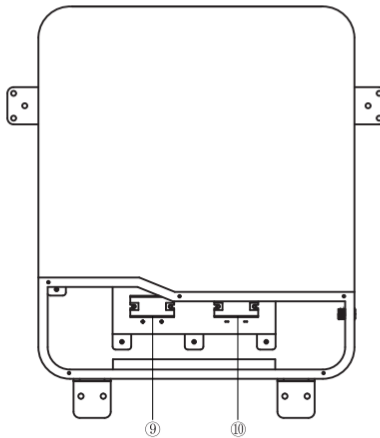
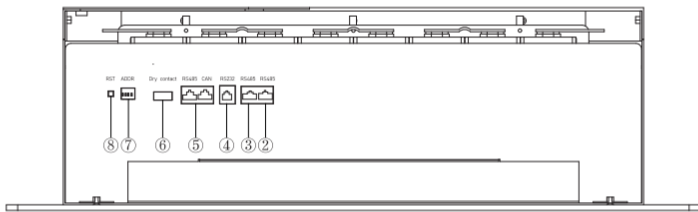

- ① Switch ② RS485 ③ RS485 ④ RS232 ⑤ CAN/RS485(External Communication)  
 ⑥ Dry contact ⑦ ADD ⑧ RST ⑨ Battery + ⑩ Battery -

# Parallel Connection Of Batteries

Connect the positive pole and positive pole in parallel, and the negative pole and negative pole in parallel, as shown in the figure below

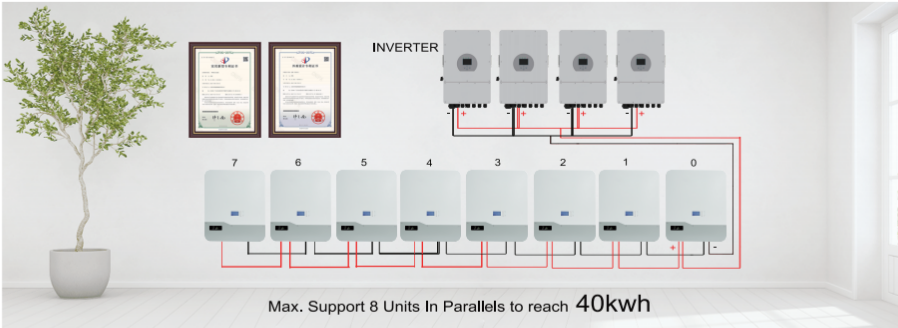

## Solution Diagram

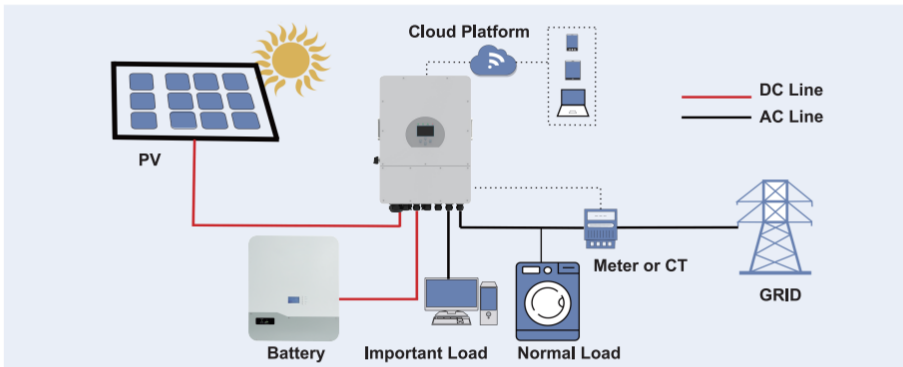

## Accessories:(Optional)

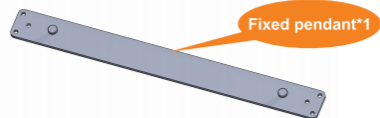
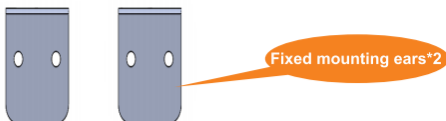
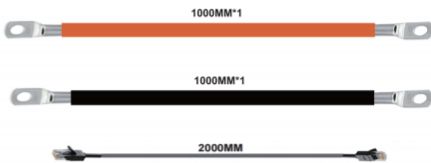

## Installation Notes:

1. As shown in the figure below, press the fixed pendant on the wall surface with one hand, use a marker to draw the installation positioning hole of the fixed pendant, and use a tool to drill.



2. As shown in the figure below, fix the attached six M8 expansion bolts in the opening of the pendant, and tighten the nuts on the bolts.

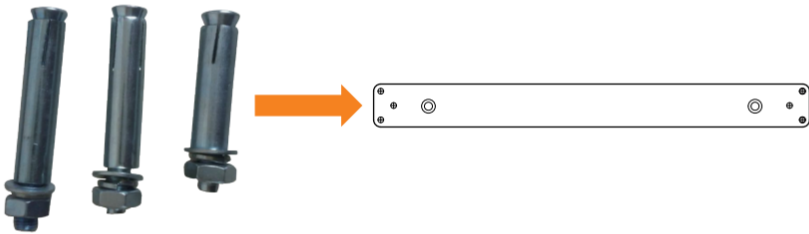

3. Lift up the 51.2V100AH battery box, adjust the opening of the pendant on the back of the box to align with the pendant on the wall as shown in the figure below, and then use a marker to mark the mounting ears of the box, and use tools to drill holes for the mounting ears.

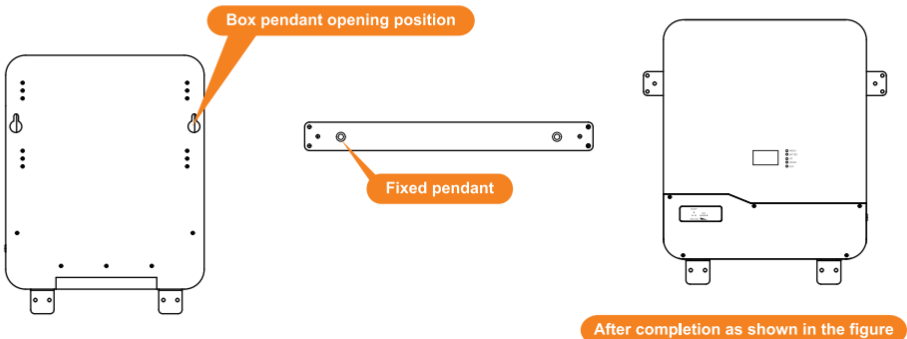

# LED Instructions

| State     | Normal / alarm / protection   | RUN      | ALM      | The power level indicates the LED  |          |          |          | Explain  |
|-----------|---|----------|----------|--|----------|----------|----------|--|
|           |   | ●        | ●        | ●  | ●        | ●        | ●        |  |
| Shut down | Dormancy  | off      | off      | off  | off      | off      | off      | All off  |
| Standby   | Normal  | Flash 1  | off      | According to the electricity instruction   |          |          |          | Stand by   |
|           | Alarm   | Flash 1  | Flash 3  |  |          |          |          | Module low voltage   |
| Charge    | Normal  | Lighting | off      | According to the electricity instruction (Power level indicates maximum LED flash 2) |          |          |          | Alarm when overvoltage light off                                 |
|           | Alarm   | Lighting | Flash 3  |  |          |          |          |  |
|           | Overcharge protection   | Lighting | off      | Lighting   | Lighting | Lighting | Lighting | If there is no charging, the indicator light is in standby state |
|           | Temperature, overcurrent, protection  | off      | Lighting | off  | off      | off      | off      | Stop charging  |
| Discharge | Normal  | Flash 3  | off      | According to the electricity instruction   |          |          |          |  |
|           | Alarm   | Flash 3  | Flash 3  |  |          |          |          |  |
|           | Undervoltage protection   | off      | off      | off  | off      | off      | off      | Stop discharge   |
|           | Temperature, over-current, short-circuit, Reverse connection and failure protection | off      | Lighting | off  | off      | off      | off      | Stop discharge   |
| Fail      |   | off      | Lighting | off  | off      | off      | off      | Stop charging and discharging                                    |

**Table 1 LED working status indication**

| State                    |           | Charge  |          |          |          | Discharge |          |          |          |
|--------------------------|-----------|---------|----------|----------|----------|-----------|----------|----------|----------|
| Capacity indicator light |           | L4      | L3       | L2       | L1       | L4        | L3       | L2       | L1       |
| Battery Power(%)         | 0 ~ 25%   | off     | off      | off      | Flash 2  | off       | off      | off      | Lighting |
|                          | 25 ~ 50%  | off     | off      | Flash 2  | Lighting | off       | off      | Lighting | Lighting |
|                          | 50 ~ 75%  | off     | Flash 2  | Lighting | Lighting | off       | Lighting | Lighting | Lighting |
|                          | 75 ~ 100% | Flash 2 | Lighting | Lighting | Lighting | Lighting  | Lighting | Lighting | Lighting |

**Table 2 Capacity indication instructions**

| Flash mode | Bright | off   |
|------------|--------|-------|
| Flash, 1   | 0.25S  | 3.75S |
| Flash, 2   | 0.5S   | 0.5S  |
| Flash, 3   | 0.5S   | 1.5S  |

**Table 3 LED flash instructions**

Note: can enable or prohibit LED indicator light alarm through the upper machine, the factory default is enabled.

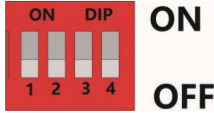

| Address | Codes the switch position |     |     |     |
|---------|---------------------------|-----|-----|-----|
|         | #1                        | #2  | #3  | #4  |
| 1       | OFF                       | OFF | OFF | OFF |
| 2       | ON                        | OFF | OFF | OFF |
| 3       | OFF                       | ON  | OFF | OFF |
| 4       | ON                        | ON  | OFF | OFF |
| 5       | OFF                       | OFF | ON  | OFF |
| 6       | ON                        | OFF | ON  | OFF |
| 7       | OFF                       | ON  | ON  | OFF |
| 8       | ON                        | ON  | ON  | OFF |
| 9       | OFF                       | OFF | OFF | ON  |
| 10      | ON                        | OFF | OFF | ON  |
| 11      | OFF                       | ON  | OFF | ON  |
| 12      | ON                        | ON  | OFF | ON  |
| 13      | OFF                       | OFF | ON  | ON  |
| 14      | ON                        | OFF | ON  | ON  |
| 15      | OFF                       | ON  | ON  | ON  |
| 16      | ON                        | ON  | ON  | ON  |

Table 5 Dial switch position

## Interface Definition

Diagram diagram of the communication interface

RS232 communication port definition:

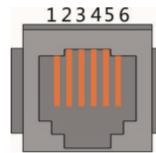

| Interface                              | Defined declaration |   |
|--|---------------------|---|
| X7<br>Communication port<br>definition | PIN 1               | NC(empty)   |
|  | PIN 2               | NC(empty)   |
|  | PIN 3               | TX protection board sends data (computer receiving data foot) |
|  | PIN 4               | RX protection board receives data (computer sends data)       |
|  | PIN 5               | Ground signal ground  |
|  | PIN 6               | NC(empty)   |

Table 6 The RS 232 Port Definition

## RS485-1 / CAN Communication Interface Definition:

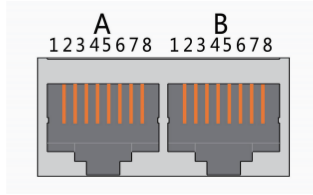

| Interface                              | Defined declaration  |       | Defined declaration |                                 |       |           |
|--|----------------------|-------|---------------------|---------------------------------|-------|-----------|
| X1<br>Communication port<br>definition | A part<br>CAN joggle | PIN 1 | CANL                | B part<br>RS-485-1<br>Interface | PIN 1 | RS485-B1  |
|  |                      | PIN 2 | CGND                |                                 | PIN 2 | RS485-A1  |
|  |                      | PIN 3 | NC(empty)           |                                 | PIN 3 | RS485-GND |
|  |                      | PIN 4 | CANH                |                                 | PIN 4 | RS485-B1  |
|  |                      | PIN 5 | CANL                |                                 | PIN 5 | RS485-A1  |
|  |                      | PIN 6 | NC(empty)           |                                 | PIN 6 | RS485-GND |
|  |                      | PIN 7 | CGND                |                                 | PIN 7 | NC(empty) |
|  |                      | PIN 8 | CANH                |                                 | PIN 8 | NC(empty) |

Table 7 The RS 485-1 / CAN port definition

## RS485-2 Communication Interface Definition:

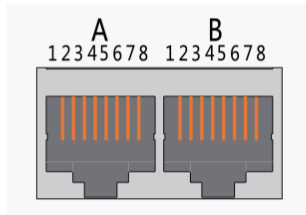

| Interface                              | Defined declaration             |       | Defined declaration |                                 |       |           |
|--|---------------------------------|-------|---------------------|---------------------------------|-------|-----------|
| X2<br>Communication port<br>definition | A part<br>RS-485-2<br>Interface | PIN 1 | RS485-B2            | B part<br>RS-485-2<br>Interface | PIN 1 | RS485-B2  |
|  |                                 | PIN 2 | RS485-A2            |                                 | PIN 2 | RS485-A2  |
|  |                                 | PIN 3 | RS485-GND           |                                 | PIN 3 | RS485-GND |
|  |                                 | PIN 4 | NC(empty)           |                                 | PIN 4 | NC(empty) |
|  |                                 | PIN 5 | NC(empty)           |                                 | PIN 5 | NC(empty) |
|  |                                 | PIN 6 | RS485-GND           |                                 | PIN 6 | RS485-GND |
|  |                                 | PIN 7 | RS485-A2            |                                 | PIN 7 | RS485-A2  |
|  |                                 | PIN 8 | RS485-B2            |                                 | PIN 8 | RS485-B2  |

Table 8 The RS 485-2 port definition

## Dry Contact Description :

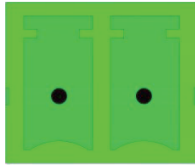

1 2

KRY1 (2EDG-3.81-2P) Interface

This BMS can provide one channel of dry contact signal, all dry contact signals are passive switches, regardless of polarity.

| KRY1 (2P terminal)      |                         |  |
|-------------------------|-------------------------|--|
| BMS State               | Description             | Remark   |
| When BMS normal working | 1/2 pin is disconnected |  |
| When BMS protected      | 1/2 pin is connected    | Output when SOC alarm, under voltage and over voltage alarm and BMS protection state, such as under voltage protection, over voltage protection or short circuit protection; |

## Button Operation Instructions

- When the BMS is in sleep state, press the button for more than 1S, the protection board is activated.
- When the BMS is in the working state, when the duration of pressing the button is more than 3S and less than 6S, the BMS enters the sleep state.
- When the BMS is in working state, the protection board will reset when the button is pressed for more than 6S.

## Buzzer Action Description

- Turn on the power and the buzzer will beep for a long time
- Shut down to sleep, the buzzer beeps briefly
- In the case of short-circuit protection, the buzzer beeps every 2S. After the short-circuit protection is locked for 3 times, the buzzer will no longer beep. The buzzer function can be enabled or disabled by the host computer, and the factory default is disabled;

When the buzzer function is disabled, the buzzer does not work when the protection board alarms and protects (except for short circuit and reverse connection protection).

## Description Of Sleep Function

In order to reduce the power consumption of the whole system, the system has a sleep function,

**when the following conditions are met, the system will enter the sleep mode:**

- 1) The over-discharge protection of the monomer has not been released for 5 minutes (the time can be set).
- 2) The duration of the standby state reaches 24 hours (no communication, no charge and discharge, no charger connect).
- 3) Operate the composite key switch according to the operation rules.

The protection board can be forced to shut down and enter the sleep mode by operating the "forced sleep" button of the upper computer.

## Wake-up Function Description

**Combined with the actual situation, for the convenience of use, the system provides a variety of different wake-up methods:**

- 1) Wake up from charging, connect to the charger, and the voltage of the charger is greater than 36V;
- 2) Wake up by button;
- 3) Communication wake-up, you can wake up through RS485-1, RS232 port and CAN communication;

Please note that the battery enters sleep mode due to single or overall over-discharge, and cannot be woken up by serial port.

## Current Limiting Function Description

The BMS has the charging current limiting function, the maximum charging current limiting is  $10\pm 1$  A, the user can set the current limiting startup condition and the current limiting function on and off through the upper computer;

The default start-up condition of charging current limit is to start when the charging current is greater than 30A. After entering the current limit, the test will be performed again every 10 minutes. When the current is less than the current limit start value, the current limit function will be turned off. When the current is bigger than the current limit start value, then always in current limiting mode.

## Communication Description

1. RS232 data upload and parameter setting function

BMS has RS232 communication function for battery pack data upload and parameter modification setting. The default baud rate is 9600bps, and the RS232 communication interface is RJ12 network port.

It can communicate with the upper computer software through the RS232 port, can read and monitor the status and information of the battery pack in real time, and can re-modify and set the parameters of the BMS.

## 2. CAN communication software upgrade and inverter communication function

The BMS have the CAN communication function for the interactive communication between the battery pack data and the inverter, the default baud rate is 500Kbps, and the CAN communication interface is the RJ45 network port.

The BMS has the CAN communication function of software upgrade. The default baud rate is 500Kbps.

## 3. RS485-1 communication and inverter or EMS communication function

The BMS have the RS485 communication function for the interactive communication between the battery pack data and the inverter, the default baud rate is 9600bps, and the RS485-1 communication interface is the RJ45 network port.

The BMS should have the RS485 communication function for interactive communication with the network management system (EMS). The default baud rate is 9600bps.

## 4. RS485-2 data upload and communication parallel function

BMS has RS485 communication function for battery pack data upload and RS485 uplink and cascade communication function. The default baud rate is 9600bps, and the RS485-2 communication interface is dual RJ45 network ports.

Through the RS485-2 port, the upper computer software can communicate, and the status and information of the battery pack can be read and monitored in real time. (RS485 communication cannot modify parameters)

# Parallel (cascade) Function Of Battery Packs

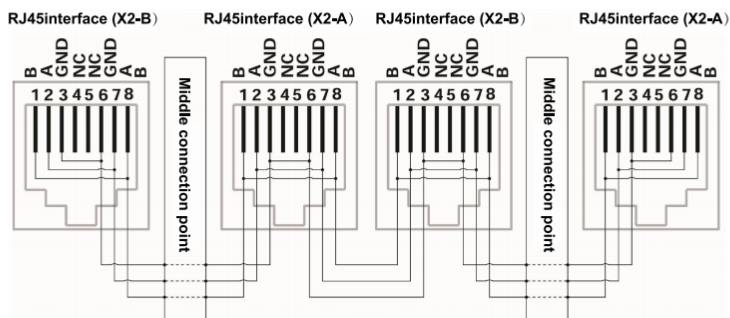

When the battery packs are cascaded, the one with the communication address of 0001 is called the master battery pack, and the other ones with the communication address are called the slave battery packs. The slave battery pack can communicate with the master battery pack through the RS485 communication interface, and the master battery pack centrally packs and manages the data of each battery pack in this cascaded system.

When the battery packs are cascaded, only the main battery pack can communicate with the host computer, upload the data, status and information of all battery packs in the cascaded system, integrate monitoring and management, and realize remote monitoring.



# RS485 Parallel Wiring Diagram

When performing multi-machine parallel communication operation, it is necessary to configure the DIP address of each PACK first. The dialing code adopts BCD code format, the definition

of address 1 is  (black dot is OFF state, blank is ON state, the same below), address 2 is defined as , Address 3 is defined as , and so on for other addresses.

## Upper PC Software

The software model of the upper computer is "BMS monitoring system (V2.1A ZW202201)".

You can read the operating status of the protection board such as voltage, current, temperature, alarm and protection through the host computer software, set the parameters of the BMS, view the historical records of the protection board, and open the function module of the BMS.

## Warning

To ensure proper use of the battery please read the manual carefully before using it.

### ● Handling

- Do not expose to, dispose of the battery in fire.
- Do not put the battery in a charger or equipment with wrong terminals connected.
- Avoid shorting the battery
- Avoid excessive physical shock or vibration.
- Do not disassemble or deform the battery.
- Do not immerse in water.
- Do not use the battery mixed with other different make, type, or model batteries.
- Keep out of the reach of children.

### ● Charge and discharge

- Battery must be charged in appropriate charger only.
- Never use a modified or damaged charger.
- Do not leave battery in charger over 24 hours.

### ● Storage

- Store the battery in a cool, dry and well-ventilated area.

### ● Disposal

- Regulations vary for different countries. Dispose of in accordance with local regulations.

# Battery Operation Instruction

## ● Charging

Charging current: Cannot surpass the biggest charging current which in this specification book stipulated.

Charging voltage: Does not have to surpass the highest amount which in this specification book stipulated to decide the voltage.

Charge temperature: The battery must carry on the charge in the ambient temperature scope which this specification book stipulated.

Uses the constant electric current and the constant voltage way charge, the prohibition reverse charges. If the battery positive electrode and the cathode meet instead, can damage the battery.

## ● Discharging current

The discharging current does not have to surpass this specification book stipulation the biggest discharging current, the oversized electric current electric discharge can cause the battery capacity play to reduce and to cause the battery heat.

## ● Electric discharge temperature

The battery discharge must carry on in the ambient temperature scope which this specification book stipulated.

## ● Over-discharges

After the short time excessively discharges charges immediately cannot affect the use, but the long time excessively discharges can cause the battery the performance, battery function losing. The battery long-term has not used, has the possibility to be able to be at because of its automatic flash over characteristic certain excessively discharges the condition, for prevented excessively discharges the occurrence, the battery should maintain the certain electric quantity.

## ● Battery storage

The battery should store in the product specification book stipulation temperature range. If has surpasses above for six months the long time storage, suggested you should carry on additional charge to the battery.

## ● Warranty

The period of warranty is 5 years from the date of shipment. GENIXGREEN guarantees to give a replacement in case of cells with defects proven due to manufacturing process instead of the customers abuse and misuse.

● **Other chemical reactions**

Because batteries utilize a chemical reaction, battery performance will deteriorate over time even if stored for a long period of time without being used. In addition, if the various usage conditions such as charge, discharge, ambient temperature, etc. are not maintained within the specified ranges the life expectancy of the battery may be shortened or the device in which the battery is used may be damaged by electrolyte leakage. If the batteries cannot maintain a charge for long periods of time, even when they are charged correctly, this may indicate it is time to change the battery.