

Key Features

- ◆ Off grid hybrid solar inverter SUB-EL/SUB-E 3.5/5.5KW ,PF=1
- ◆ 3 in 1 design , Inverter + MPPT controller + AC Charger
- ◆ Solar,Grid and Battery Energy complement each other,priority selectable
- ◆ Working without battery during daytime
- ◆ High efficiency sine wave output,Minimal self-consumption
- ◆ Wide MPPT range 30Vdc--160Vdc or 60VDC-500VDC, 60 or 100A adjustable
- ◆ Intelligent 3 stage AC battery charger, 60 or 80A adjustable
- ◆ Surge Twice the rated power for 5 seconds
- ◆ Monitor, troubleshoot, or communication with RS485/RS232. Model SUB-E3500 with RS232 only
- ◆ Wifi Module option for App display Function

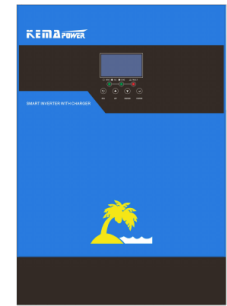

Technical Specifications

ITEM	Model	SUB-E3500	SUB-EL3500L	SUB-E5500L
OUTPUT	RATED POWER	3.5KW	3.5KW	5.5KW
	Waveform	Pure Sine Wave		
	Voltage	230Vac±5%		
	Frequency	50Hz or 60Hz		
	Surge Power	2* rated power for 5 seconds		
	Overload Protection	5s@≥140% load; 10s@100%~140% load		
	Short Circuit Protection	Line mode: Circuit Breaker Battery mode: Electronic Circuits		
	Efficiency,PV to INV.	0.94		
	Efficiency,Battery to INV.	>95% (Rated R load, battery full charged)		
	Transfer Time	10ms typical (UPS);20ms typical (Appliances)		
Parallel Extension	infeasible			
NO BAT working	YES			
ON GRID TIE OUTPUT	NO			
GRID INPUT	Nominal Input Voltage	230VAC		
	Max Input Voltage	300VAC		
	Acceptable Voltage Range	170-280VAC(For personal Computer); 90-280vac(For Home Appliances)		
	Low Loss Voltage	170VAC±7V (For UPS); 90VAC±7V (For Home Appliances)		
	Low Loss Return Voltage	180VAC±7V (For UPS); 100VAC±7V (For Home Appliances)		
	High Loss Voltage	280VAC±7V		
	High Loss Return Voltage	270VAC±7V		
	Normal Frequency	50Hz / 60Hz (Auto detection)		
	Low Loss Frequency	40Hz±1Hz		
	Low Loss Return Frequency	42Hz±1Hz		
High Loss Frequency	65Hz±1Hz			
High Loss Return Frequency	63Hz±1Hz			
Communication interface	RS232, WIFI (Optional)	RS485/RS232, WIFI (Optional)	RS485/RS232, WIFI (Optional)	RS485/RS232, WIFI (Optional)
BATTERY & GRID CHARGER	Battery type	Lead Acid	Lead Acid,Lithium	Lead Acid,Lithium
	Battery Voltage	24 VDC	24 VDC	48 VDC
	Floating Charge Voltage	27 VDC	27 VDC	54VDC
	Overcharge Protection	33 VDC	33 VDC	63 VDC
	Charge Current (Max)	60 A	80A	80A
SOLAR CHARGER	PV Array Power (Max)	4000W	1500W	5500W
	MPPT Range	120Vdc~450Vdc	30Vdc~160Vdc	60Vdc~500Vdc
	PV Array VOC (Max)	500 VDC	160VDC	500 VDC
	Charging Current (Max)	100A	60A	100A
	Max. Input Current	15A	50A	18A
	Efficiency (Max)	0.98		
Display	LED	Line Mode or bat Mode, Charging status ,Fault		
	LCD	Vac HZ, Charge Amp W, PV VDC Amp W , Load % VA W Amp ,bat % VDC ,,setup , Fault code, working mode		
Setup/Adjust parameter	Solar power /utility power/Battery priority, united Charge Current , AC Charge Amp, AC input range, VAC HZ, Bat VDC back to utility power, BAT VDC back to Bat Mode, Charge Source select ,Alarm on off , overload bypass , Bulk/ Floating Charge VDC, Bat Low Cut VDC , equalization Charge VDC / mins / days ,			
output working Mode	utility power priority	default. Utility power priority, Solar and battery as backup when utility power not available		
	Solar priority(SUB Mode)	solar power priority, utility power supplement to load when solar power is not enough , utility not available, battery supplement to load. Working on daytime while No Bat		
	SBU priority	Solar power priority, When Solar power is not enough,battery to supplement.when battery power is not enough , utility power to load. Working on daytime while No Bat		
OPERATING ENVIRONMENT	Humidity	5% to 95% Relative Humidity (Non-condensing)		
	Operating Temperature	(-10°C - 55°C)		
	Storage Temperature	-15°C - 60°C		
Product size	L*W*H	295.4*105.5*420.2	295.4*100*340	295.4*105.5*420.2
Net Weight (kgs)	Kg	7	6	8
Carton size	L*W*H	560*185*375mm	460*175*375mm	560*185*375mm
Carton weight	Kg	8	7	9

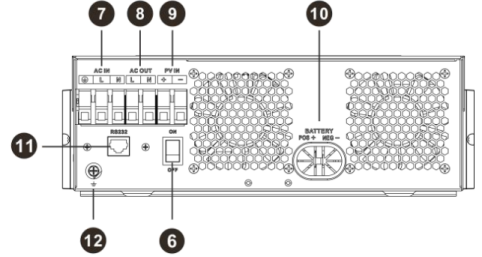
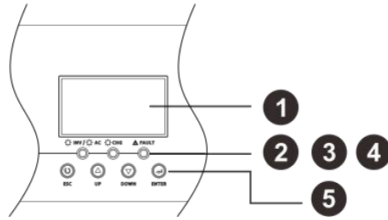
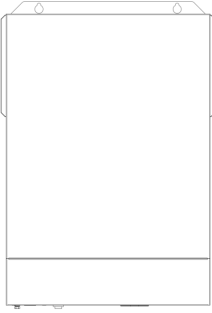
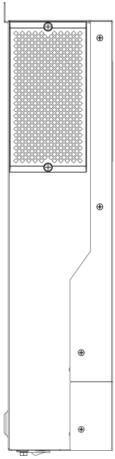

- 1. LCD display
- 2. Status indicator
- 3. Charging indicator
- 4. Fault indicator
- 5. Function buttons
- 6. Power on/off switch

- 7. AC input
- 8. AC output
- 9. PV input
- 10. Battery input
- 11. RS232 communication port
- 12. Grounding

Design layout

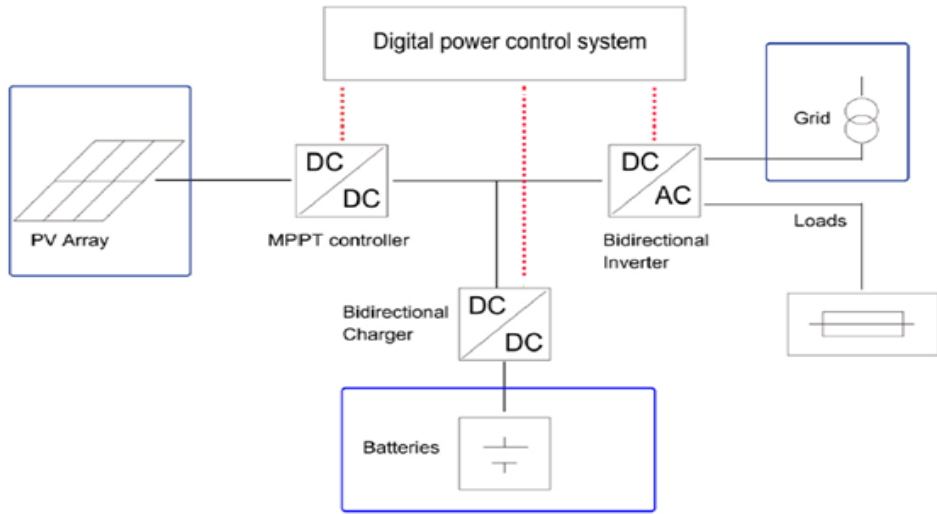

Solar Power(S) Utility Power(U) and Battery (B) into Same BUS Voltage.
Solar + Utility+ Battery Power Power(U) Are Complement each other

System Diagram

Option with Battery Connected

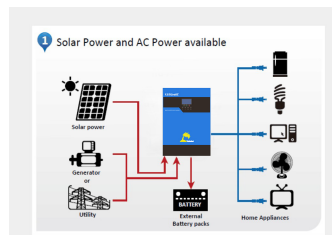
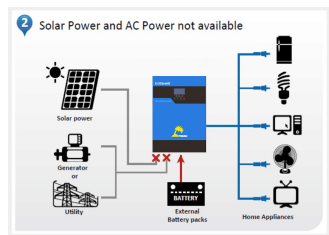
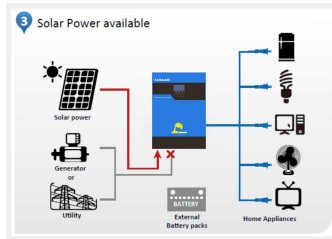
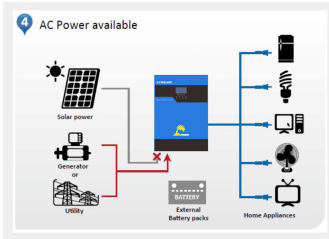

Working Mode and Output Source Priority

Output Working	Solar Charging	AC Charging	Output Source Priority			Battery Disconnect
			1	2	3	
utility power priority	yes.unless No sunshine	selectable	Utility power	Solar	Battery	Working when solar available
Solar priority(SUB Mode)	yes.unless No sunshine	selectable	Solar	Utility power	Battery	Working when solar available
SBU priority	yes.unless No sunshine	selectable	Solar	Battery	Utility power	Working when solar available

please reference above working mode